

THREE-POINT CAMS CLASSIC STEEL

Three-point cams for use with housings with external limitation of rotation. Stroke: 20 mm. Supplied with E-clips.

In the drawing, A = the projection, C = housing length, H = outside face to engagement point of cam.

Other lengths and versions available on request.

MATERIAL

Cam: Steel, zinc plated

RELATED PRODUCTS

Rods: 2-540, 2-541, 2-545

Protective cap: 2-480

Other materials: 2-490

Use the Index Code at industrilas.com

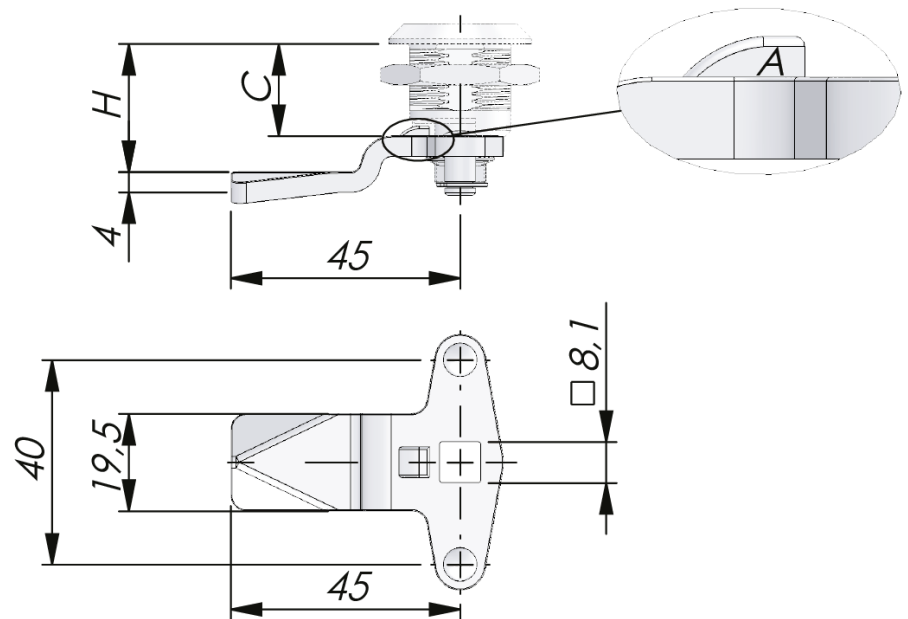

P/N	Description	C=12	C=18	C=30	C=40	C=45	C=50	C=56	C=60
2321S01	---	-	4	16	26	31	36	42	46
2321S02	---	-	6	18	28	33	38	44	48
2321S03	---	2	8	20	30	35	40	46	50
2321S04	---	4	10	22	32	37	42	48	52
2321S05	---	6	12	24	34	39	44	50	54
2321S07	---	8	14	26	36	41	46	52	56
2321S08	---	10	16	28	38	43	48	54	58
2321S09	Straight cam	12	18	30	40	45	50	56	60
2321S10	---	14	20	32	42	47	52	58	62
2321S11	---	16	22	34	44	49	54	60	64
2321S12	---	18	24	36	46	51	56	62	66
2321S14	---	20	26	38	48	53	58	64	68
2321S15	---	22	28	40	50	55	60	66	70
2321S16	---	24	30	42	52	57	62	68	72
2321S17	---	26	32	44	54	59	64	70	74
2321S18	---	28	34	46	56	61	66	72	76
2321S20	---	30	36	48	58	63	68	74	78
2321S21	---	32	38	50	60	65	70	76	80
2321S22	---	34	40	52	62	67	72	78	82
2321S23	---	36	42	54	64	69	74	80	84
2321S24	---	38	44	56	66	71	76	82	86
2321S27	---	44	50	62	72	77	82	88	92
2321S28	---	42	48	60	70	75	80	86	90
2321S29	---	40	46	58	68	73	78	84	88

H in mm when housing length C=12, 18, 30, 40, 45, 50, 56 or 60 mm.